



A-dec 422 Assistant's Stool with Torso Support

INSTALLATION GUIDE

Required Tools

- 1/8" hex key
- 7/16" and 9/16" combination wrenches

Figure 1. A-dec 422 Assistant's Stool



Assemble the Stool Base

1. Remove the five casters and the stool base from the kit.
2. Insert the casters fully into the base and press them firmly to secure them.

Figure 2. Attach the Casters to the Stool Base

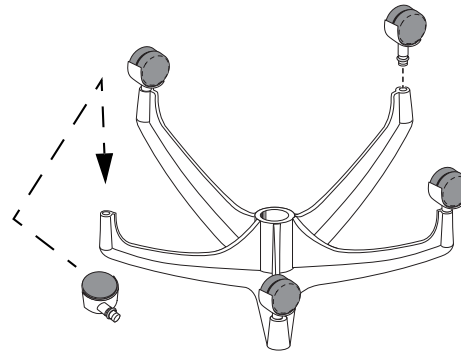

3. Insert the cylinder through the foot ring; then into the stool base assembly.

Figure 3. Foot Ring and Stool Base Assembly

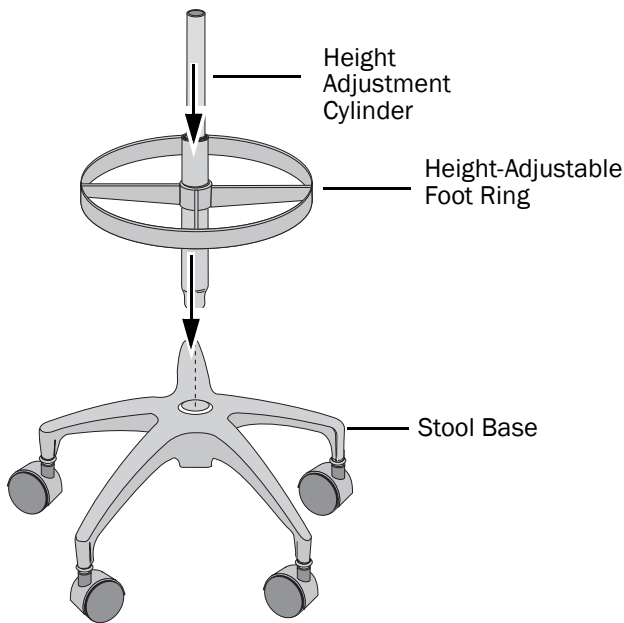

CAUTION A gas cylinder for height adjustment is integrated into the cylinder. As you press the cylinder firmly in place, do not hit the cylinder directly.

Install the Stool Seat

1. Use a 7/16" combination wrench and the four short bolts and washers to attach the stool seat to the swivel assembly and the base plate.
2. Guide the mounting block onto the top of the cylinder and push down, so that the height adjustment cylinder is firmly seated in both the stool base assembly and the seat assembly.



TIP The cylinder uses a self-locking taper. Press down firmly to ensure that the cylinder is fully seated in the mounting block.

Figure 4. Stool Seat Assembly

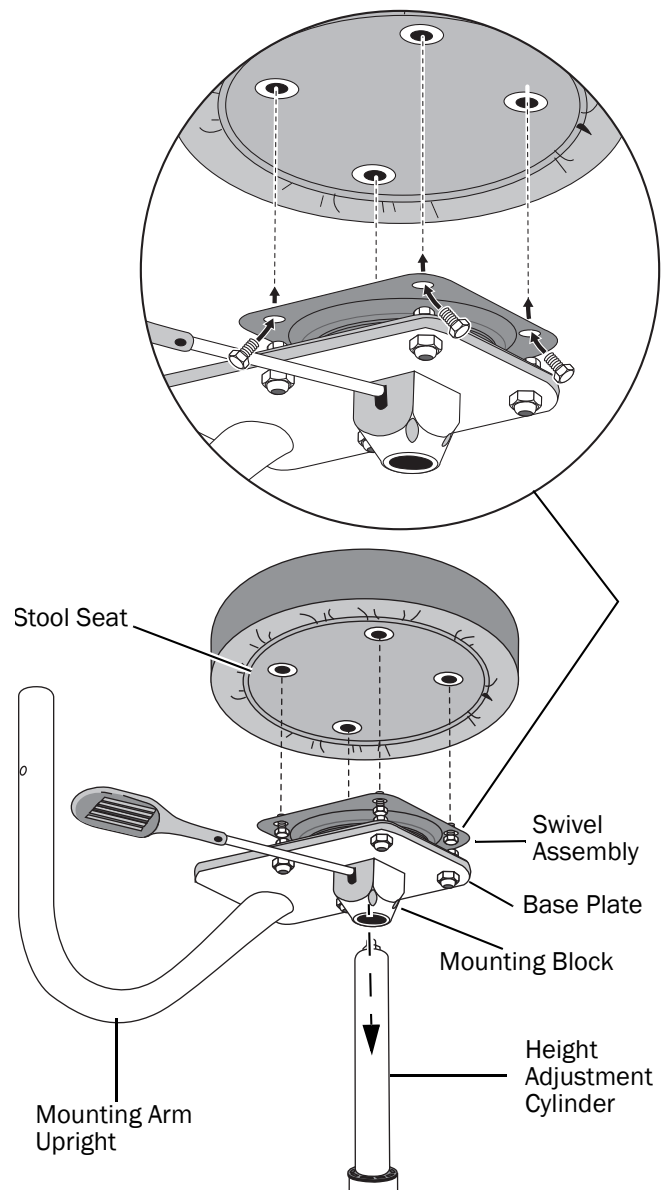

Attach the Torso Support

1. Use a 9/16" combination wrench and the two washers and two long bolts to install the torso support to the mounting arm upright.

Figure 5. Attach the Torso Support

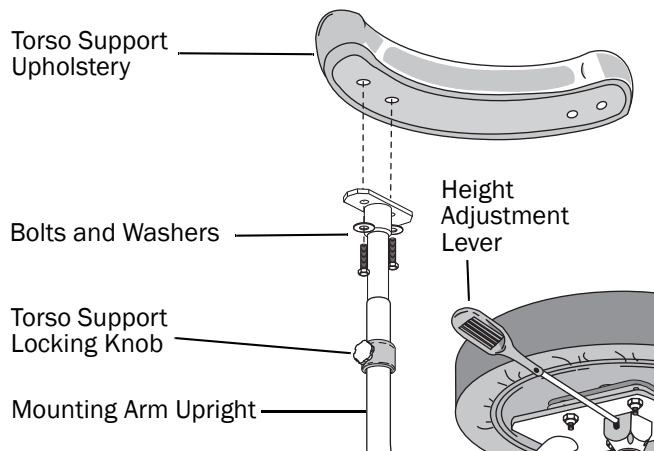

Test and Adjust the Stool

1. Sit on the stool and ensure that the cylinder is completely seated.
2. Adjust the seat to a comfortable position.
 - Use the height adjustment lever to raise and lower the seat.
 - Use the torso support locking knob to change the height of the torso support.

Adjust the Stool Foot Ring

1. Position the height-adjustable foot ring to the desired height.
2. Use a 1/8" hex key to tighten the two set screws to hold the foot ring in position.

Figure 6. Adjust the Height of the Foot Ring

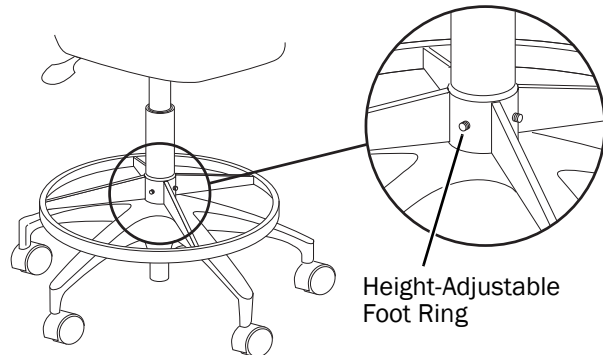

Regulatory Information

Regulatory information mandated by agency requirements is provided in the *Regulatory Information, Specifications, and Warranty* document (p/n 86.0221.00), which is available in the Document Library at www.a-dec.com.

A-dec Headquarters

2601 Crestview Drive
Newberg, OR 97132 USA
Tel:1.800.547.1883 Within USA/Canada
Tel:1.503.538.7478 Outside USA/Canada
Fax:1.503.538.0276
www.a-dec.com / www.a-dec.biz

A-dec Inc. makes no warranty of any kind with regard to the content in this document including, but not limited to, the implied warranties of merchantability and fitness for a particular purpose.



85.0504.00 Rev C
Copyright 2015 A-dec Inc.
All rights reserved.
IGevbw6