

A-dec 586 Ceiling Monitor Mount

Recommended Tools

- 7/16" wrench
- Socket set and ratchet with 6" extension
- Phillips head and standard screwdrivers
- Diagonal cutters
- Level
- 3/8" drill with a 3/16" drill bit
- 2-1/8" to 2-1/4" hole saw
- Hex key set

Important Information

Check with local building and code authorities about installation requirements specific to your location.



CAUTION Use a SJT type cable when connecting power to the monitor. SJT cables are more durable than the SVT cables typically provided by monitor manufacturers and are required when routed through moving arms. Use a monitor that weighs 20 lb or less and fits on a 75 mm or 100 mm VESA pattern mount. Always follow local building and electrical codes.



NOTE Not all parts included in this kit may be necessary for your particular installation or configuration.



Determine the Mounting Location

1. Determine the mounting location for the ceiling monitor mount in relation to the dental chair.
2. Ask the doctor to determine if a left or right hand installation is preferred.



NOTE The image below shows the recommended locations to place the A-dec ceiling monitor mount. The primary recommendation for each system minimizes light and monitor arm interference. These recommendations work with all A-dec dental chairs.

Recommended Mounting Locations (B - Head of Baseplate, C - Centerline of Chair, S - Side of Chair)

Without a Ceiling Track Light

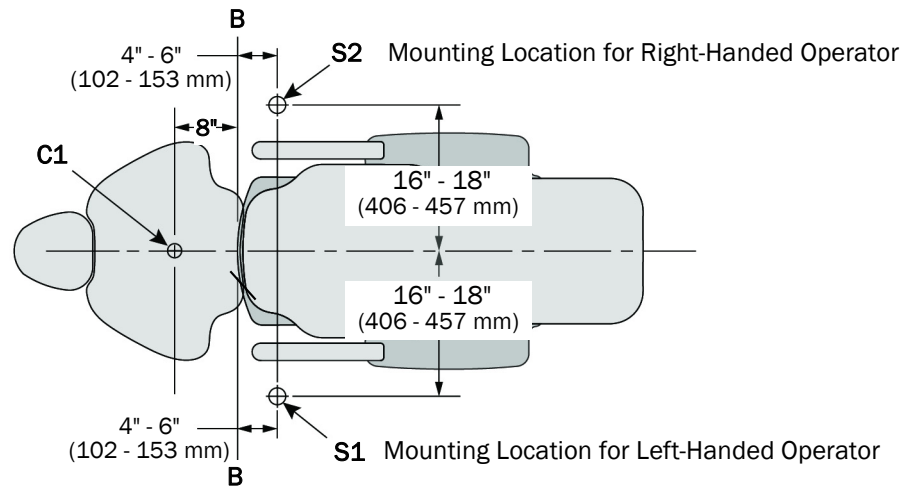

With a Ceiling Track Light

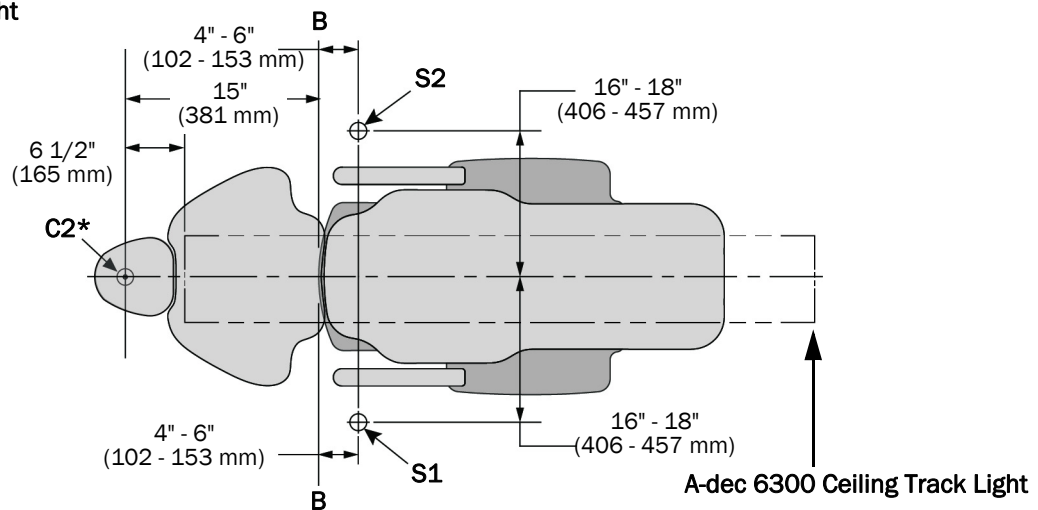

Monitor Mount and Light Compatibility

System With This Light	Primary Recommendation	Secondary Recommendation
Track-Mount Ceiling-Light	S1 or S2	C2* (See the note at the top of page 3.)
Fixed-Mount Ceiling Light	C1	S1 or S2
Chair or Cabinet Mount Lights	S1 or S2	C1



NOTE If you are installing in the C2 position, you must have a 6-1/2" space between the front of the track mount ceiling light on the center line of the baseplate and the monitor mount post location. See the image under "Recommended Mounting Locations" on page 2. A space less than 6 1/2" will result in the monitor being too close to the patient's face when the patient is upright in the chair. If you cannot obtain the minimum 6 1/2" distance, we recommend a different configuration. Contact your A-dec dealer for more information.



NOTE After the installation is complete, the monitor mount should measure a minimum of 89" (2261 mm) from the bottom of the extension arm to the floor.

Proper Installation Height

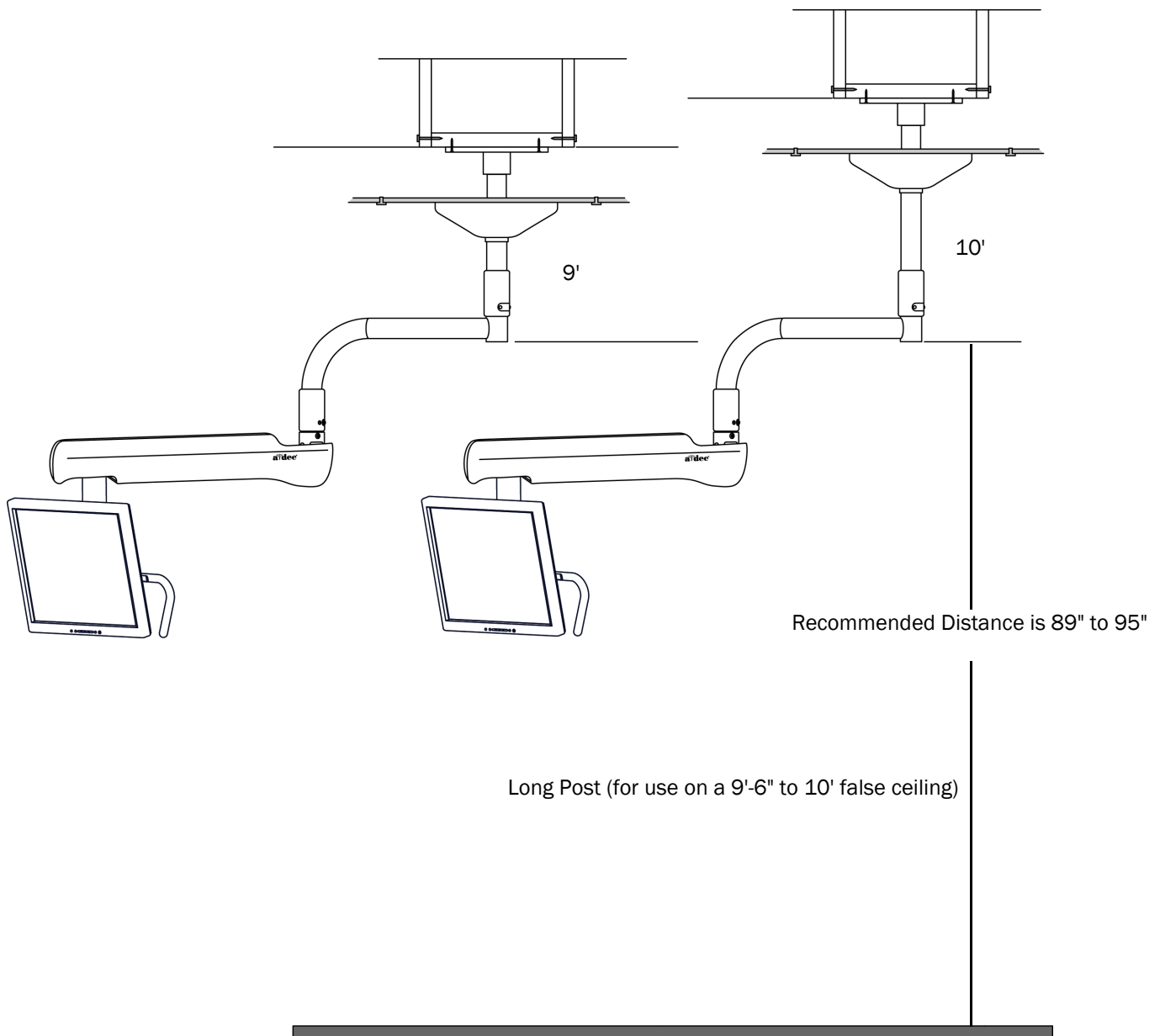

Determine the Ceiling and Bracing Type

Determine the type of ceiling (wood frame or suspended) to which the dental light is being installed and complete any required modifications to the ceiling structure.

New Construction

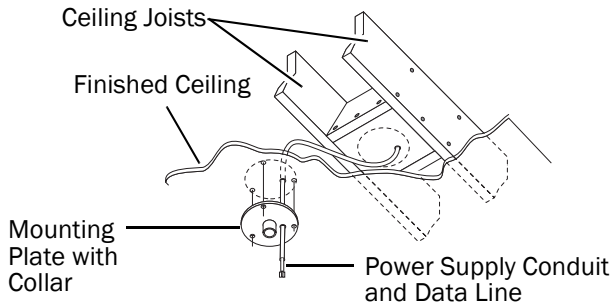

Existing Construction

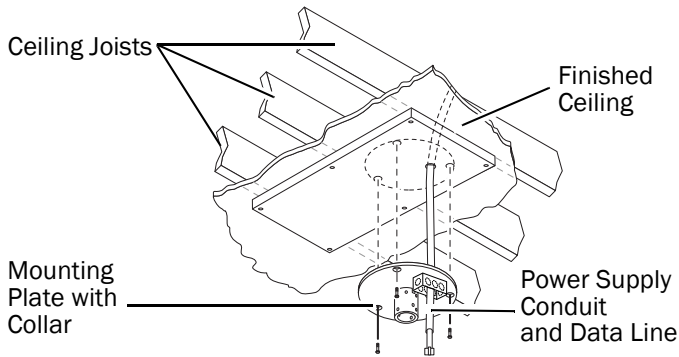

Suspended Ceiling Metal Construction

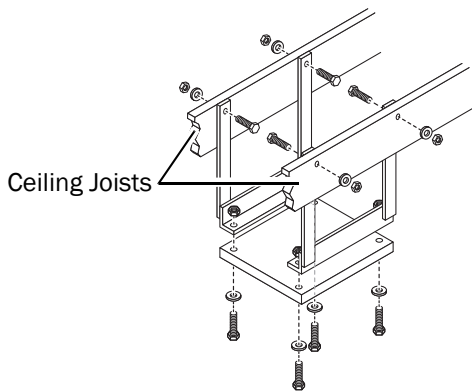

False Ceiling Mounting Structure Information

Leave a maximum of 6" (152 mm) clearance between the false ceiling and the support structure to ensure correct product height for a given ceiling height and post length.

False Ceiling

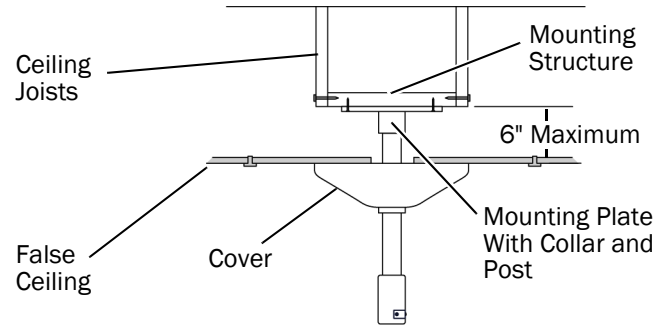

Install the Monitor Mount

Install the Ceiling Mounting Plate

1. Position the mounting template (included in the kit) on the ceiling. Mark the mounting holes, power stub, and data line.



NOTE When securing the mounting plate and post, position the collar bolt holes in relation to the chair's position as shown in the image under "Recommended Mounting Locations" on page 2. Be sure to position the threaded hole for the collar bolt next to the junction box.

2. Make sure the electrical power conduit reaches the access holes in the top of the mounting plate.
3. Drill the 3/16" (4.8 mm) diameter mounting holes.
4. Use a Phillips head screwdriver to remove the junction box cover before mounting the plate to the ceiling. Use a 7/16" socket and ratchet and the lag screws from the kit to mount the plate to the ceiling.

Install the Ceiling Mounting Plate

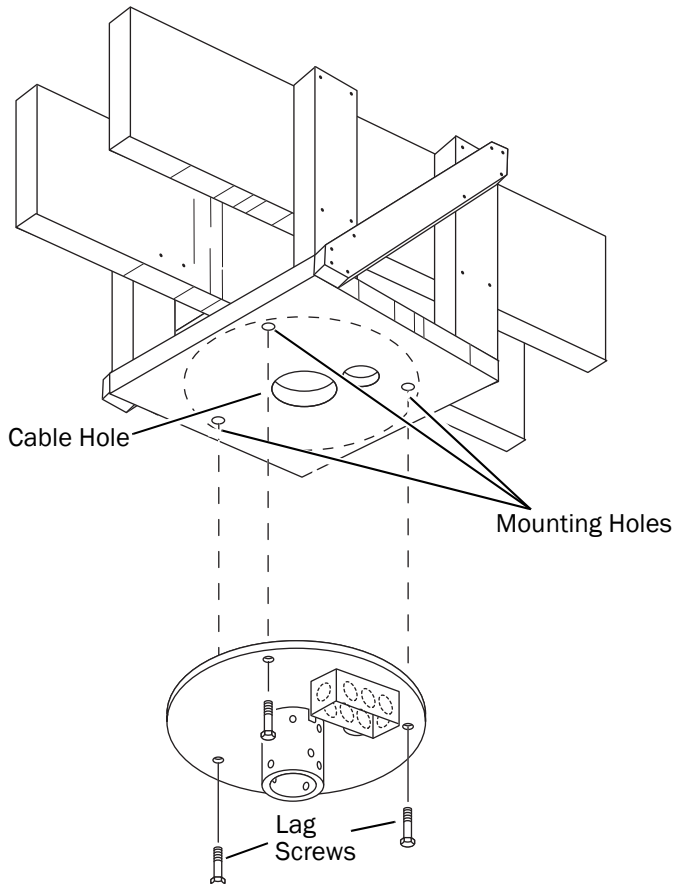

Wire and Level the Post

1. Connect the electrical wiring with wire nuts as follows:
 - Brown wire from the power cord to the black or brown wire from the electrical stub.
 - Blue wire from the power cord to the white or blue wire from the electrical stub.
 - Green/yellow wire from the power cord to the ground wire from the electrical stub, and the green wire from the junction box.

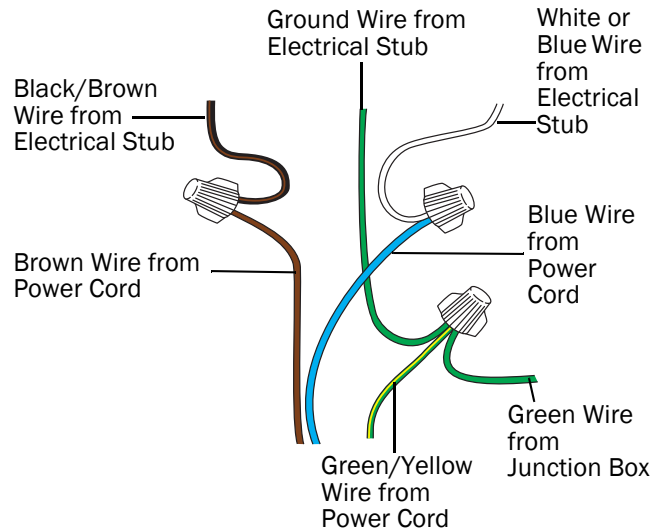

2. Replace the junction box cover. Route the power cord and audio/video cables through the post and slide the post up into the collar. For monitors with a long post, use a piece of tubing tied to the power cord to pull the cord and audio/video cables through the post.
3. Line up the holes in the post and the collar where the collar bolt installs. (It does not matter where the slot in the post faces.) Use a 7/16" socket and ratchet to install the bolt through the collar and post. Firmly tighten the bolt.

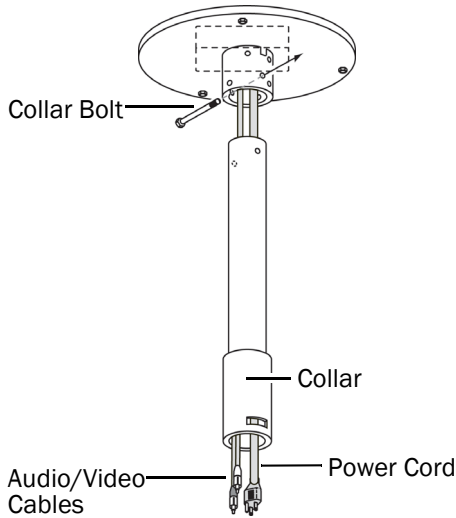

Connect the Extension Arm

1. Apply a light coat of Lubriplate™ to the extension arm groove and bushings.

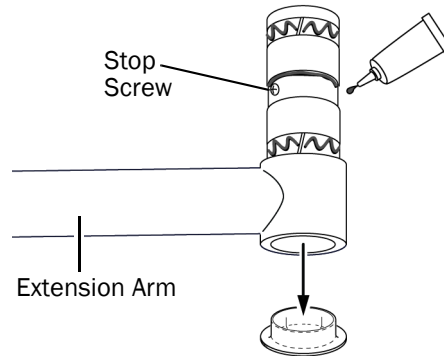

2. Lubricate the joint retainer.

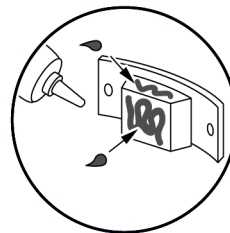

Install the Cover

1. Remove the retainer ring, and push the mount cover over the post.
2. Attach the retainer ring over the post and secure it with the cable ties. Push the mount cover up to the ceiling.

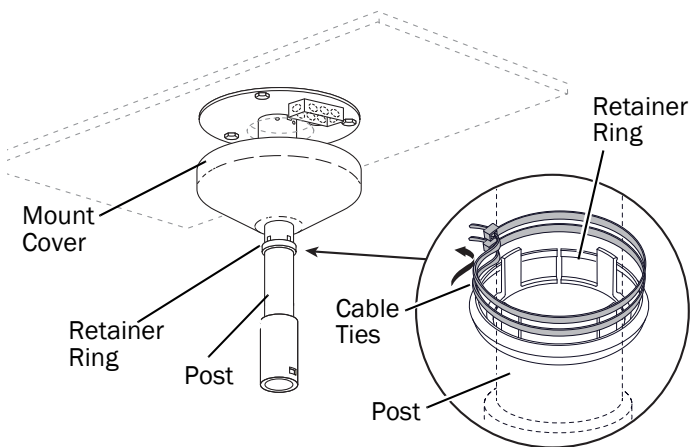

3. Insert the extension arm in the post.
4. Insert the joint retainer.



CAUTION Keep a firm hold on the extension arm to stabilize it while installing the joint retainer.

5. Use a 1/8" hex key and two 10-32 x 5/16" button head screws to secure the joint retainer.



NOTE Note the position of the stop screw before securing the extension arm. The stop screw sets the rotation limits of the extension arm. For more details, see "Stop Screw Rotation Limits" on page 10.

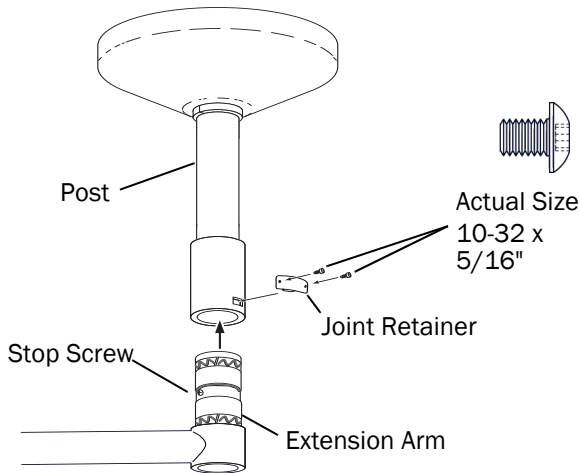

6. Remove the plug from the extension arm.
7. Route the monitor cables down through the post and the extension arm.
8. Replace the plug.

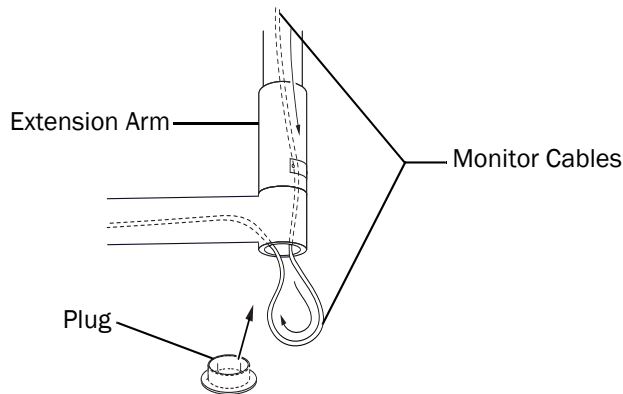

Install the Flexarm

1. Apply a light coat of Lubriplate to the flexarm adaptor groove.

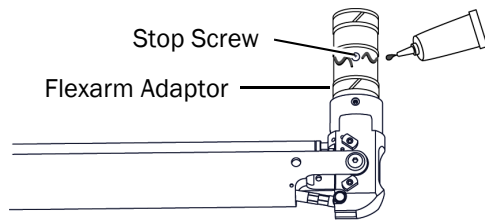

2. Lubricate the joint retainer.

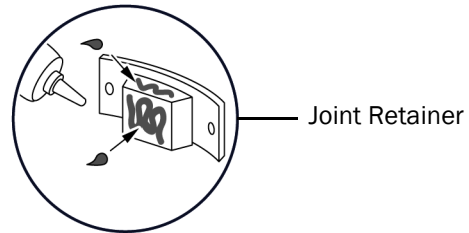

3. Insert the flexarm in the extension arm collar.



CAUTION Keep a firm hold on the flexarm to stabilize it while installing the joint retainer.

- Use a 1/8" hex key and two 5/16" button head screws to secure the joint retainer.

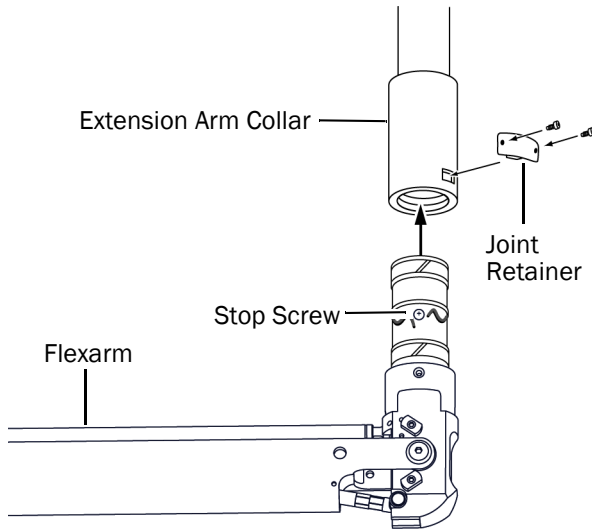

NOTE Note the position of the stop screw before securing the flexarm. For more details, see "Stop Screw Rotation Limits" on page 10.

- Route the monitor cables down through the extension arm, and then through the flexarm knuckle.

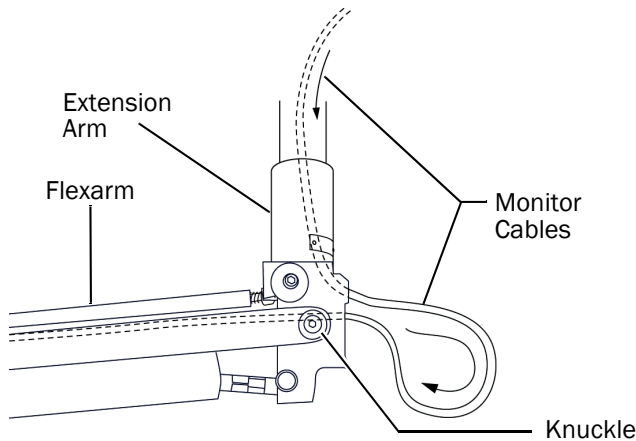

Install the Monitor

NOTE The ceiling monitor mount is designed to accommodate:

- A medical grade monitor
- 20 lb (9 kg) maximum monitor weight
- Either a 75 mm or 100 mm VESA pattern mount
- Only monitors configured with an internal power supply

- If the mounting holes on the monitor are recessed, use four 10-32 x 3/8" screws and nuts to install the recessed adaptor.

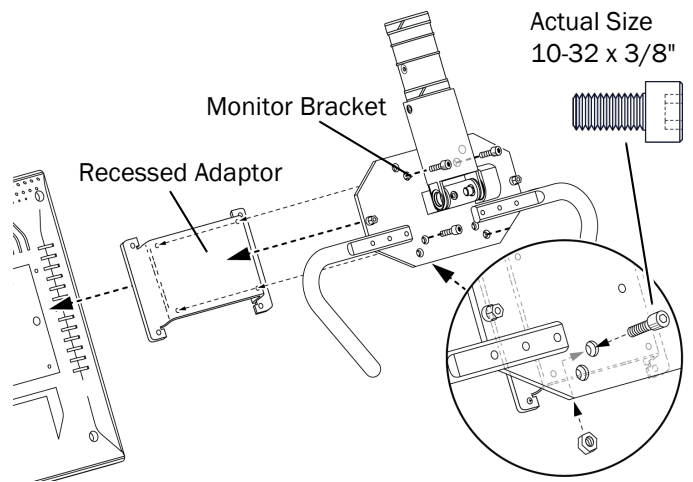

- Attach the monitor to the monitor bracket. Use the four screws that are shipped with the monitor.

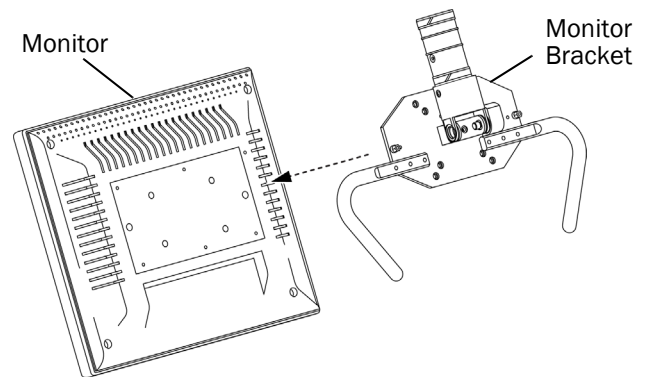

Install the Monitor Rotation Adaptor

1. Lubricate the monitor rotation adaptor and joint retainer.

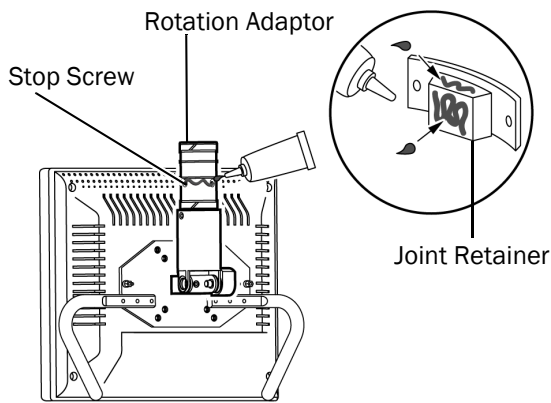

2. Route the monitor cables down through the adaptor.

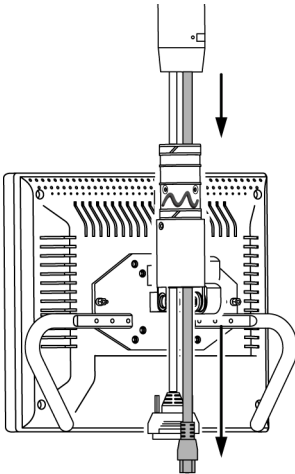

3. Insert the monitor adaptor in the flexarm.
4. Secure the joint retainer with the two screws.



CAUTION Keep a firm hold on the extension arm to stabilize it while installing the joint retainer.



NOTE Take note of the position of the stop screw before securing the monitor bracket. For more details, see "Stop Screw Rotation Limits" on page 10.

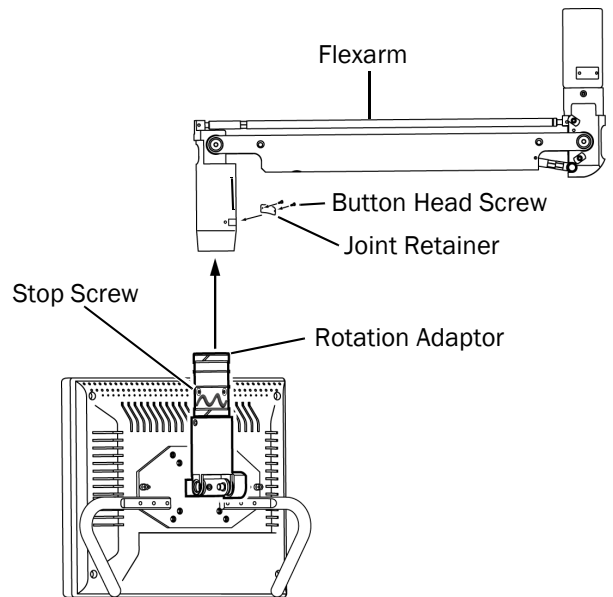

Adjust the Monitor Mount

Stop Screw Rotation Limits

The image below shows the three locations and the limits of the stop screws.

Recommended Stop Screw Locations

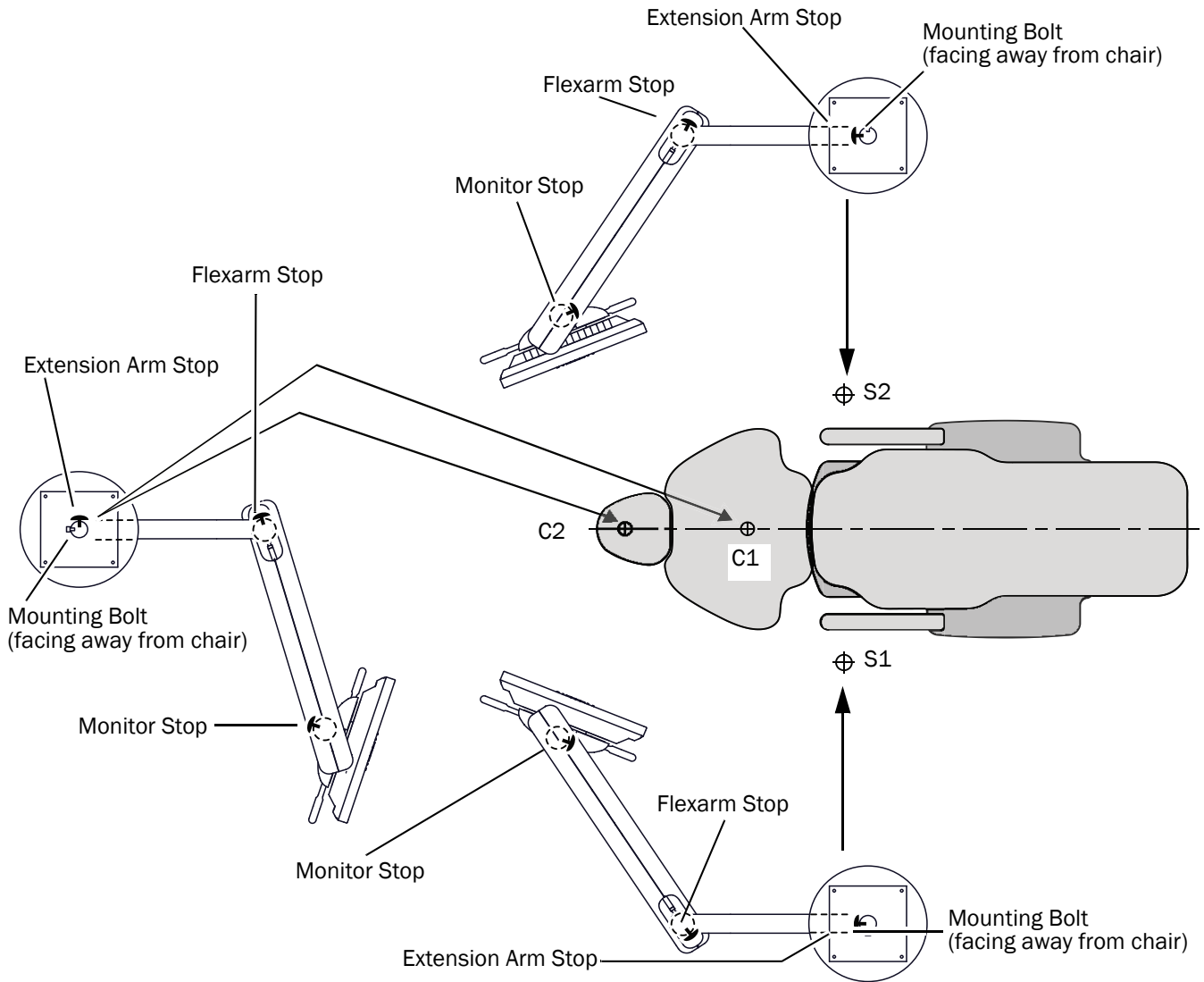

Change the Rotation Stop Location

The stop screw sets the rotation limits. There are three joint locations (monitor, flexarm, and extension arm), with four stop screw positions at each location that rotate 310° from stop to stop. See "Stop Screw Rotation Limits" on page 10. To achieve the proper rotation angle of the extension arm, flexarm, or monitor adaptor, you must relocate the stop screw to one of the four stop screw positions.

1. Use a 1/8" hex key to remove the screws securing the joint retainer, and then remove it.
2. Rotate the extension arm, flexarm, or adaptor until the stop screw is visible.

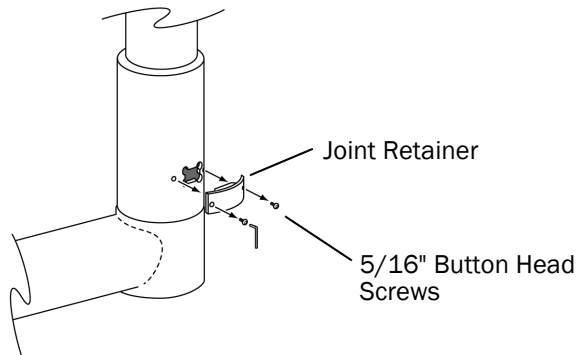

3. Use a Phillips head screwdriver to remove the stop screw.
4. Rotate the extension arm, flexarm, or adaptor to locate the new mounting hole location.
5. Install the stop screw.
6. Rotate the arm away from the stop screw, then reinstall the joint retainer.

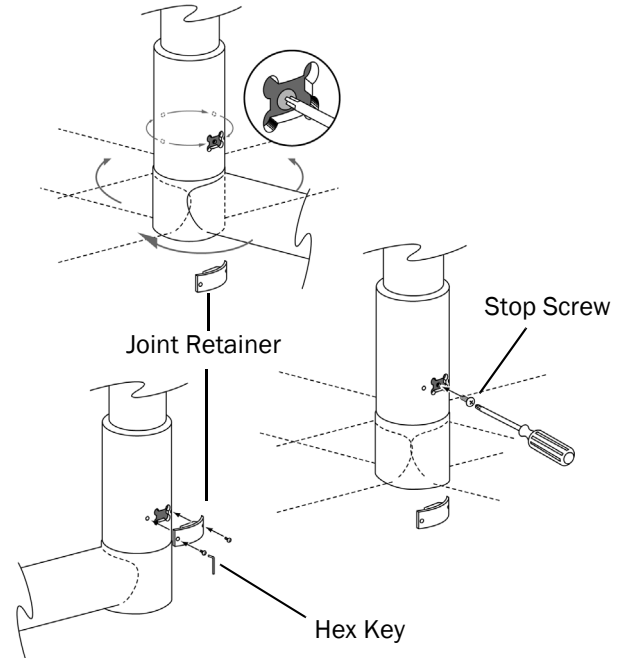

Adjust the Monitor Handles

Use a 5/32" hex key to remove the screws securing the monitor handles to the monitor. Move the handles to the desired position and secure them with the screws.

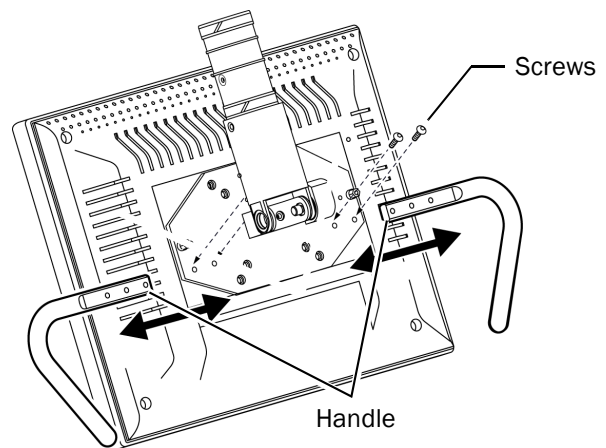

Adjust the Tilt Friction

The tilt friction adjustment allows you to adjust the pivot tension of the monitor. Use a 5/32" hex key to adjust the tilt friction.

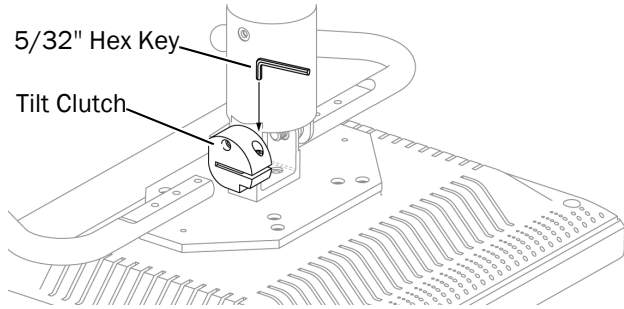

Adjust the Lower Vertical Post

1. Use a 7/16" wrench to adjust the alignment of the monitor to the flexarm.

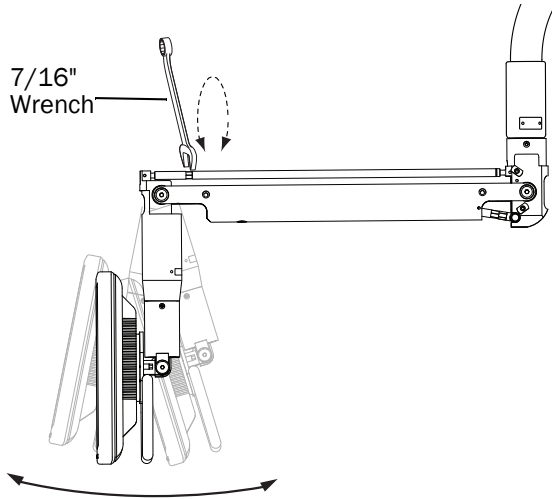

Adjust the Flexarm Counterbalance

When you install the monitor, the flexarm might drift slightly up or down. If the flexarm drifts down, see "Increase the Tension". If it drifts up, see "Decrease the Tension".

Increase the Tension

Use a 7/16" wrench to turn the nut. Do not rotate the nut past the second groove.

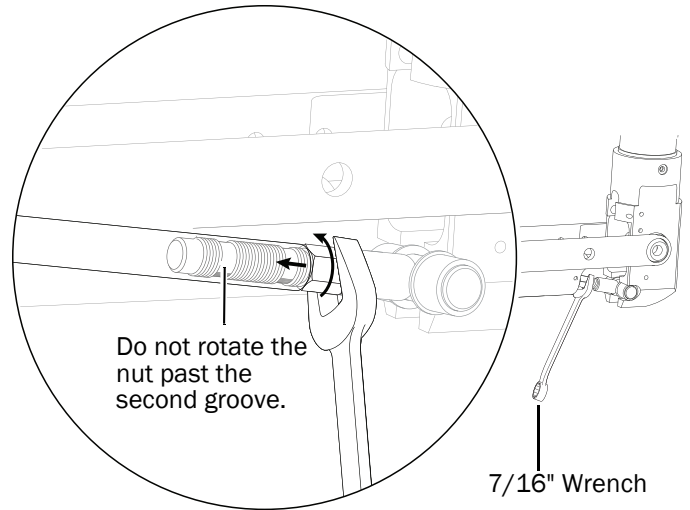

Decrease the Tension

Use a 3/8" socket and ratchet with a 6" extension to loosen the bolt at the front of the flexarm. The factory preset for this bolt is all the way in so initially you can only loosen the bolt.

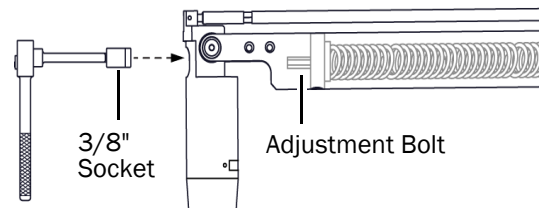

Install the Covers

Install the Monitor Bracket Cover

1. Use a 1/8" hex key to attach the monitor bracket cover using the two screws provided.

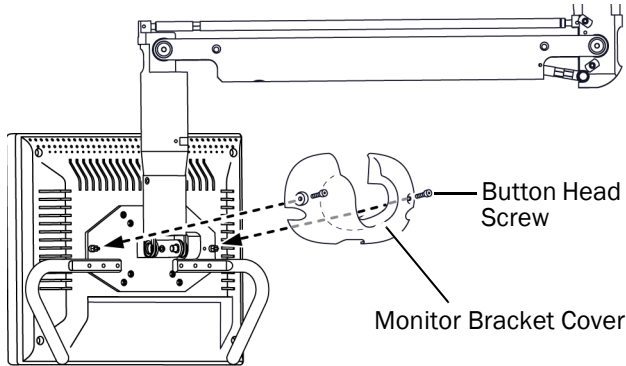

NOTE The monitor mount bracket cover is designed to accommodate monitors configured with an internal power supply.



CAUTION When removing or replacing covers, take care not to damage any wiring or tubing. Verify that the covers are secure after replacing them.

Install the Flexarm Covers

1. Insert the two posts of the attached cover into the outside holes on the flexarm.
2. Use a 5/32" hex key through the access hole and two 1/4-20 x 1/2" screws to secure the cover.
3. Line up the ball snaps and snap the covers together.

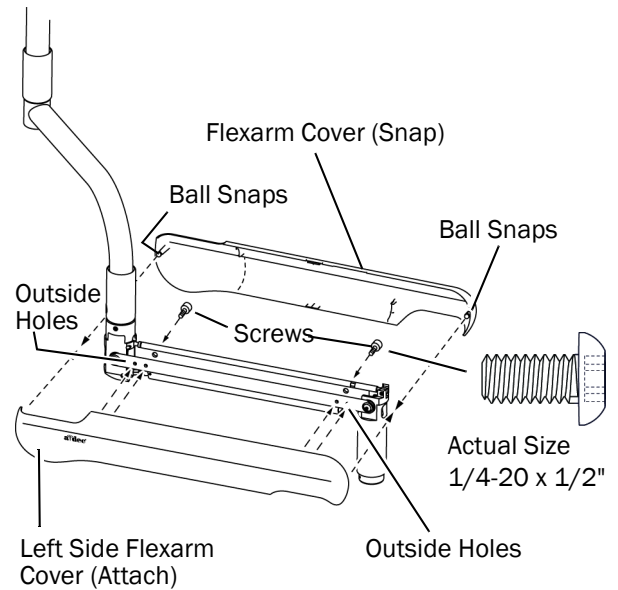

Regulatory Information

Regulatory information mandated by agency requirements is provided in the *Regulatory Information, Specifications, and Warranty* document (p/n 86.0221.00), which is available in the Document Library at www.a-dec.com.

Lubriplate is a trademark of the Lubriplate Lubricants Co.

A-dec Headquarters

2601 Crestview Drive
Newberg, OR 97132 USA
Tel: 1.800.547.1883 Within USA/CAN
Tel: +1.503.538.7478 Outside USA/CAN
www.a-dec.com

A-dec Inc. makes no warranty of any kind with regard to the content in this document including, but not limited to, the implied warranties of merchantability and fitness for a particular purpose.



Product Models and Versions Covered in This Document

Models	Versions	Description
A-dec 586	A	Monitor Mount



86.0066.00 Rev J
Date of Issue 2020-02-10
Copyright 2020 A-dec Inc.
All rights reserved.
IGporeven12